

EXTRA300L 30CC

Item No : A-G030010

Specifications

Wing Span	73" (1860mm)
Length	68" (1730mm)
Wing Area	1025sq in (66.1sq dm)
Flying Weight	9.7-11lbs (4400g-5000g)
Glow	91-1.20(2C) 1.10-1.40(4C)
Gasoline	26-35cc gas DLE 30/35RA MLD35 JC30Evo
Electric	6-8S Lipo
Radio	4CH/5-6 servos

Description

Covering Material	Genuine Oracover
Carbon Fibre :	Spinner, wing tube and sleeves, landing gear, tail gear; Fibreglass servo arms, horn and reinforced U/C mounting Scale read deck Canister ready tunnel Pre plumbed tank Adjustable pushrods Ringed cowl Pre drilled hinges

2 Colour schemes



A-G030010A

Blue: ORACOVER 21-050
Ferrari Red: ORACOVER 21-023
Light red: ORACOVER 21-060
Yellow: ORACOVER 21-032



A-G030010B

White: ORACOVER 21-010
Yellow: ORACOVER 21-033
Blue: ORACOVER 21-052

Unpacking

Carefully unpack the model making sure that if you use a sharp knife to open bags, not to cut any covering on the model. Inspect each item to make sure no transit damage has happened. If you are not happy with any part or are unsure please contact the Dealer that you purchased from.

Covering

Due to the model spending time in different climates zones from the factory on its way to you, some of the covering may have wrinkles. We highly recommend that you take time to re-seal all covering edges with an iron and to use a heat gun to remove any wrinkles and re-tighten the covering. It is best to do this now while the plane is not assembled, remember to not let any heat get near any parts like the canopy or cowl as this may cause damage.

Assembly Tips

We also recommend that you go over all the accessible joints with cyano glue. Wick glue into areas of high stress around the U/C plate and motor box.

Use Nutlock on all metal to metal joints. Even if you are using electric with low vibration levels it will make sure that things do not drop off your airplane!!

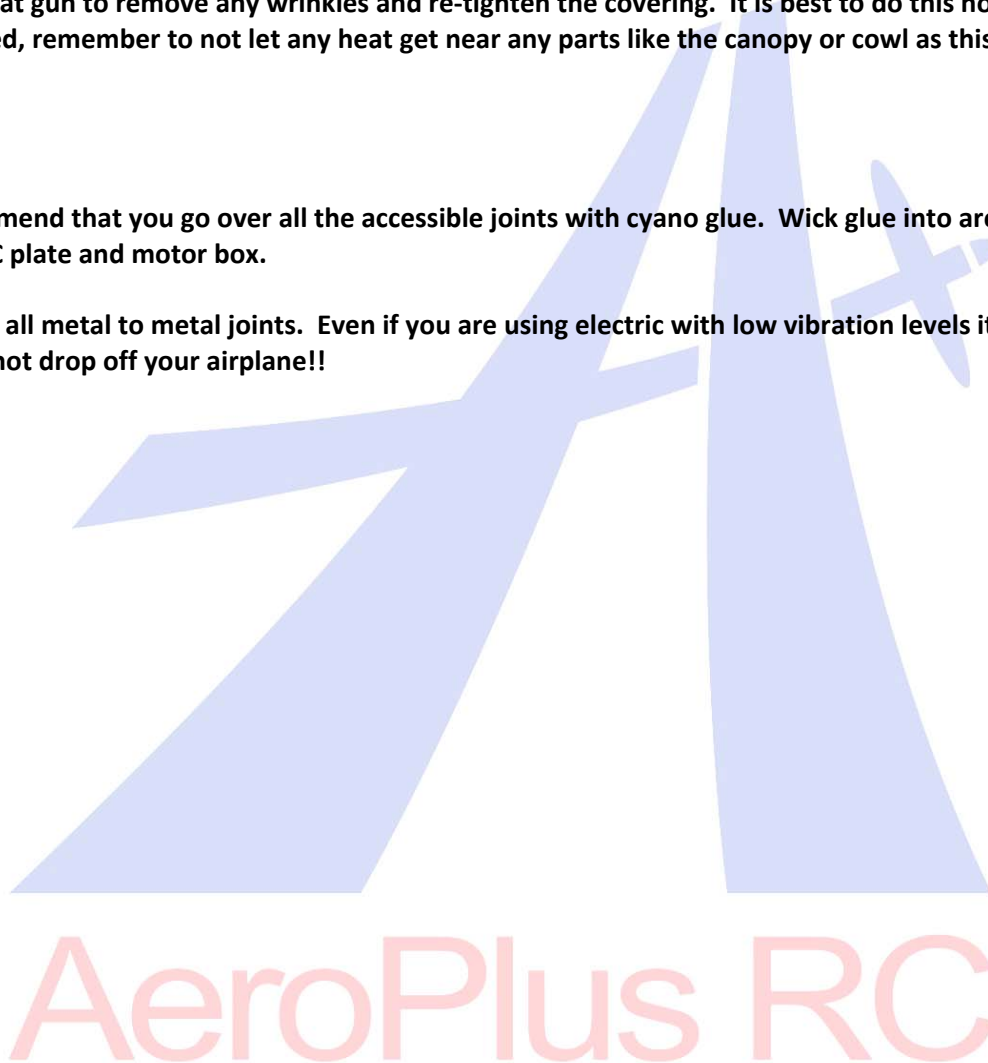

Landing Gear Assembly

To stop the fuselage getting damaged while the model is assembled we recommend fitting the landing gear first.

- Parts
CF Landing Gear
2 x wheel pants
2 x wheels
2 x axles
4 x collets
4 x M3 bolts



- Push each axle through the large holes and tighten up using 2 spanners.



- Place a collet on the axle followed by the wheel, then another collet on the outside as per below diagram.

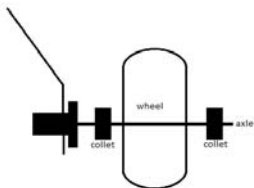

Do not tighten up the collets yet as the wheel needs to be fitted an equal distance within the wheel pant.

- The U/C rakes forward so use the correct wheel pant per side. Put nutlock onto the 2 x factory fitted blind nuts on the wheel pant



- Fit over the axle and secure with 2 x cap head bolts



- Now line up the wheel in the centre of the wheel pant opening and tighten the collets. Remember to use nutlock and to make sure the wheel can move freely.

Rear Stab

- Remove the elevators and hinges from the rear stab and place it in the opening.



It is important that care is taken when aligning the rear stab. Measure each side to make sure that an equal amount shows on each side.

- Fit the CF wing tube and looking from the front and back check that the elevator plate is in horizontal alignment to the rear stab. If it is not then trim the opening so that it is equal.
- Fit the wings and measure from the end of the wing to the elevator stab to make sure that both sides are equal

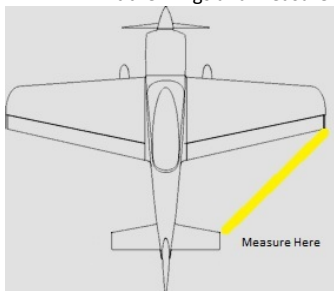

- Glueing – Once you think you are ready to glue, measure again. We recommend 2 methods for glueing. Either remove the covering on the area that is covered by the fuselage and glue with epoxy or leave the covering on and glue with thin cyno. Wicking in thin first, if a large gap is visible then use medium or thick. Remember to wick in small amounts at a time keeping the plane level, this will ensure the glue stays where it needs to be.

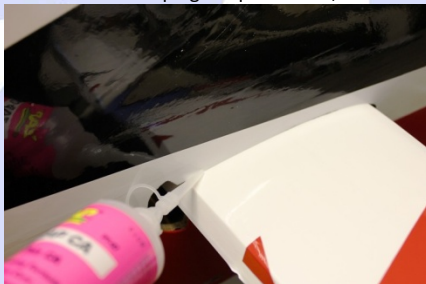

- Depending on if you are fitting 1 or 2 elevator servo's you may need to fit the elevator joining bar.



- Work out how much of the joiner bar need to go into the elevator half by laying the bar over the halves and setting the same length as the rear stab.
- Open up the covering at the inside of each of the elevator halves and mark the area of wood that needs to be removed.



- Cut the area of wood away with a sharp knife



AeroPlus RC

- Test fit the joiner bar

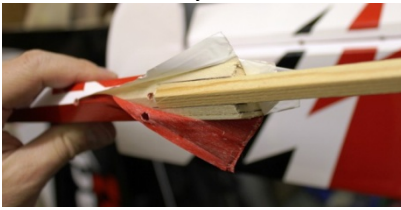

- Iron back down the covering

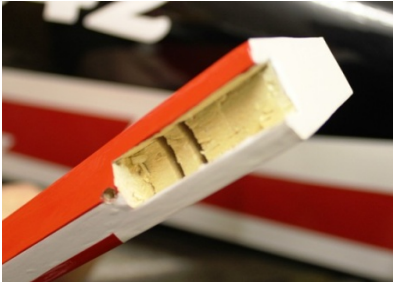

- Cover the joiner bar leaving the glue area exposed

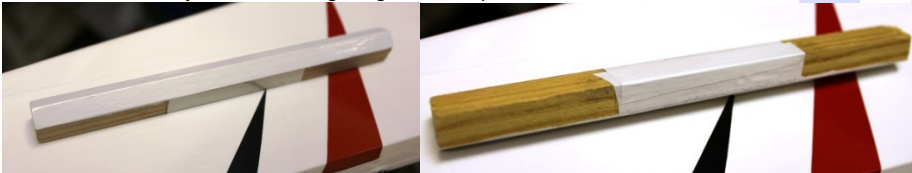

- Cut the area for the joiner bar on the other elevator half, iron down the covering and test fit.
- Glue the joiner bar into 1 of the elevator halves with epoxy.
- Now we can hinge one of the elevators with the joiner bar glued in.
- Apply 'vaseline' to the hinge point on the hinges and using 30 minute epoxy to glue these into the both the stab and elevator half. Wipe off excess glue before it sets.
- Dry fit the other elevator half with the hinges and make sure that both halves align to the stab. Trim where the joiner bar sits if required.
- Glue the hinges in both stab and elevator again with 30 minute epoxy. While gluing use tape to keep it in alignment

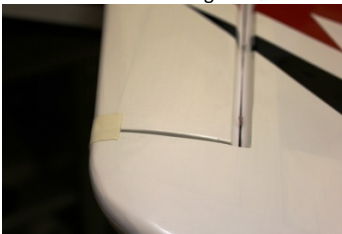

- Completed elevator



- Remove the covering for the elevator servo

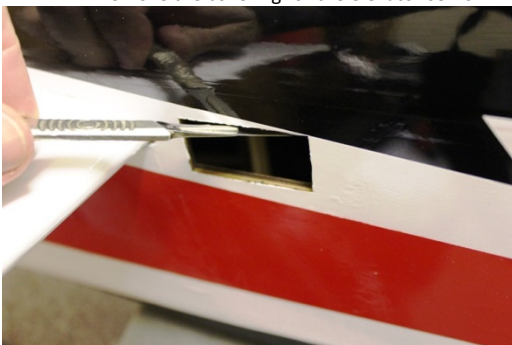

- Remove the covering where the elevator horns fit, use either a soldering iron or a sharp knife.

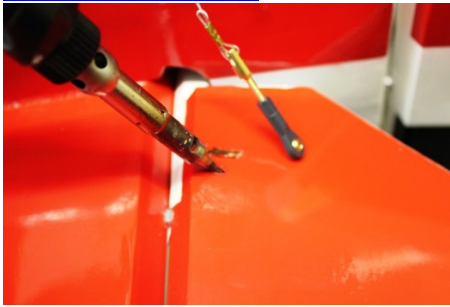

- Test fit the horns

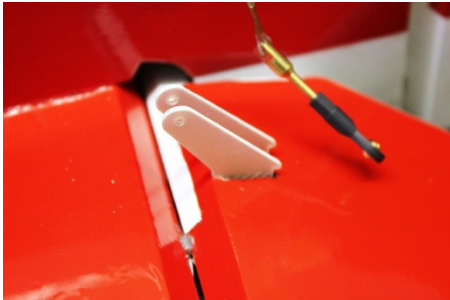

- The area on the horns that goes inside the elevator needs to be roughed up with sandpaper. This allows a better glue joint.



- Glue the horns in place with epoxy glue. Put a bolt through the ball joint hole to make sure that the horns stay in alignment while drying.



- Before fitting the elevator servo fix an extension lead so that the wire can be routed through the cardboard tube wire holder in the fuselage. On the servo lead joint add a servo plug clip.



- Fit the Elevator Servo servo and using a fine drill, drill holes for the servo screws. Remove the servo and drop thin cyano into all 4 holes.



- Re-fit the elevator servo and secure it in with servo screws.



- Centre the servo using your TX, and fit a servo arm. Use either an aftermarket arm or attach the arms that were supplied to a servo head. Screw ball joints onto the pushrod (use pliers to hold pushrod) and bolt in place with supplied bolts. Centre of servo should align with elevator flat to the stab.

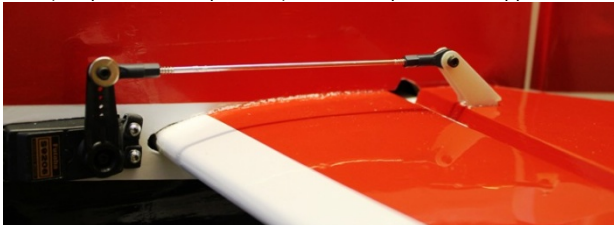
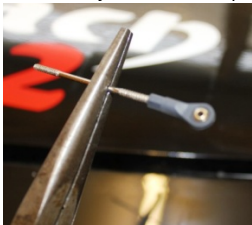

- If you are using dual elevator servos then repeat the process on the other side.

Rudder

- Remove the covering where the rudder horns push through with either a knife or soldering iron.



- Test fit the rudder horns



- Sand the area on the horn that fits inside the rudder so the glue bonds better



- Glue the rudder hinges into both the rudder and fin using epoxy glue. Remember to use vaseline on the hinge joint. While drying use tape to keep it in alignment.



- Glue the rudder horns through the rudder with epoxy, wipe off excess glue while it is wet. Use the ball joint and bolt while gluing to maintain alignment. While still movable measure that the same amount pushes out each side. Care needs to be taken here otherwise your rudder geometry will be incorrect.



- Assemble the rudder servo control arm as below, drill holes for screws and use cyno to stop the nuts from coming loose.

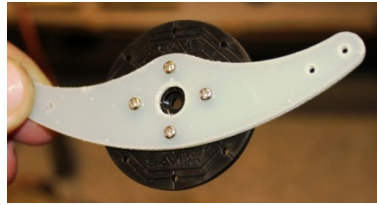

- Fit the rudder servo and drill holes using a fine drill for the servo screws, drop thin cyno into the holes to strengthen the wood.

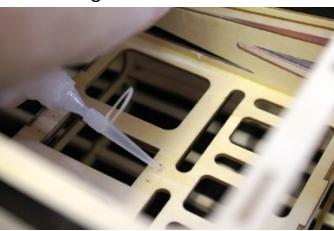
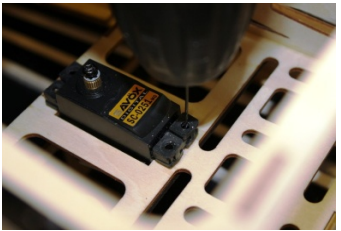

- Using servo screws fix the servo in place, note the spline is towards the front of the plane



- The closed loop wires are assembled in the plane; attach the rear ball joints to the rudder. Do this to both sides.



- Fit the arm onto the rudder servo and crimp the wires to a taut tension

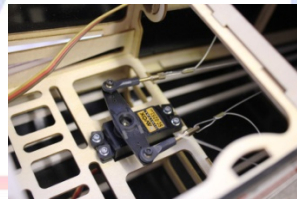

Tail Gear

- Locate all parts as in picture, when assembling remember to nutlock all parts



- Assemble the Gear as per photo



- At the rear of the fuselage you will find a ply wood area, lay the CF gear on this and mark the 3 holes. Taking care to make sure it is straight.
- Drill each hole with a fine drill and drop thin cyno into the holes to strengthen the wood.



- Screw the CF gear on with the three supplied self tapping screws.



- Drill a hole in the base of the rudder for the rudder steering guide.

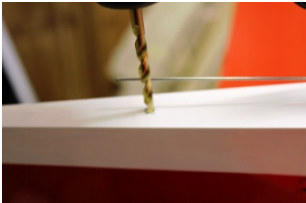

- Before gluing with cyano, place it over the thin rod.

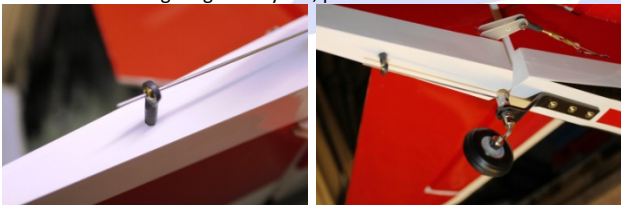

Aileron Servos

- The ailerons on the wings are pre-glued. Check each one by gently pulling to make sure that they are secure
- Remove the covering where the aileron horns are glued in place. Use either a soldering iron or a sharp knife



- Using sand paper rough the area that will be glued into the aileron.



- Glue both horns in with epoxy glue, use a bolt through the horns when gluing to make sure the alignment is correct.



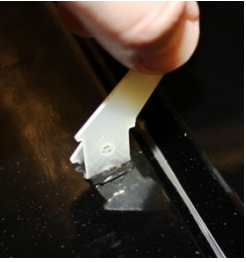

- Fit the aileron servo and drill fine holes where the servo screws will fit. Then apply thin cyano to strengthen the holes.

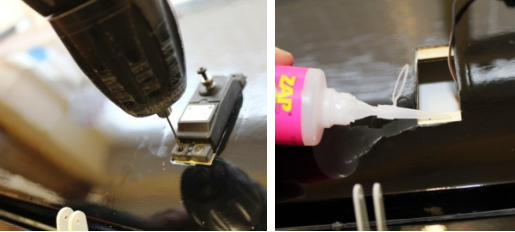

- If required install a servo extension lead onto the servo, remember to use a servo plug clip.

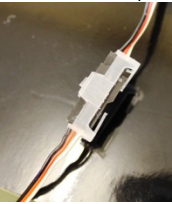

- Fit the servo and centre the servo arm.

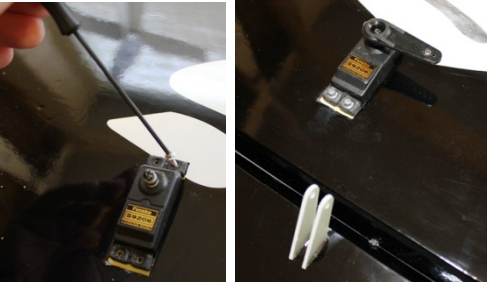

- Using the pushrod supplied screw ball joints onto each end. The correct length will leave the aileron lined up to the inner part still attached to the wing.

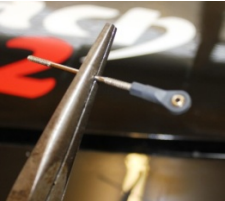

- Using supplied bolts attach the pushrod at both ends. Check to see you have sufficient movement of the aileron. If not adjust.

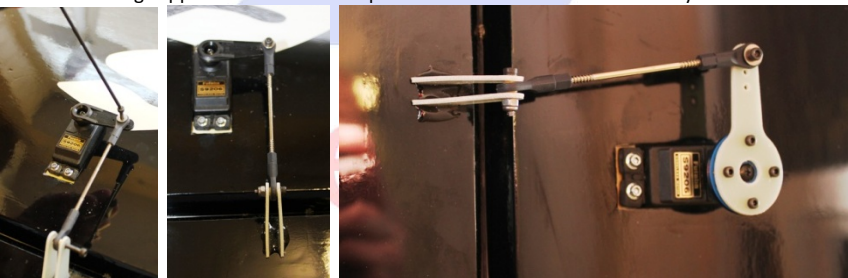

- Carry out the same procedure on the other wing.

Gas Engine

- From the template that came with the engine, using the cross axis on the engine box mark the mounting holes.



- Check the diameter of the required bolts and drill accordingly.

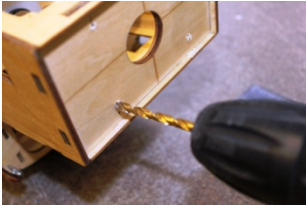

- Mount the engine with the stand offs to the bulkhead. Remember to use large washers on the inside to spread the load and use plenty of nutlock.



- Exhaust options. Depending on the engine many exhaust options are available. Standard muffler, Pitts Exhaust of canister with header.

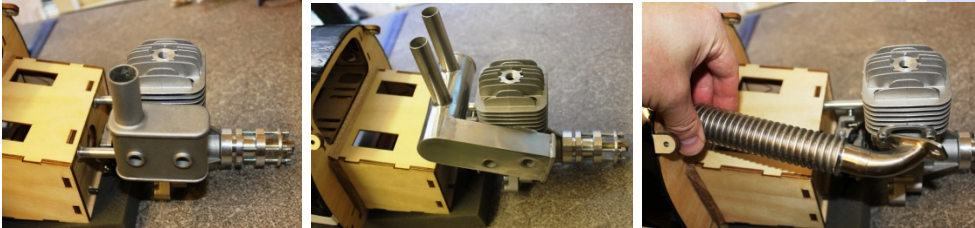

- If using a canister a bracket is already inside the model. Using silicon tubing it will hold the end of the canister.

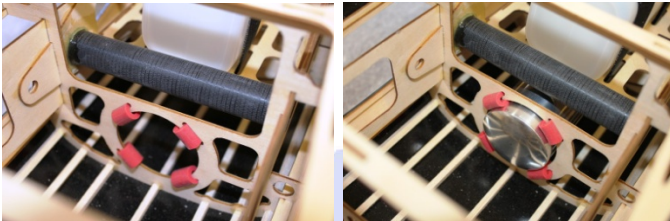

- The front outlet of the canister will pop out of the bottom of the cowl

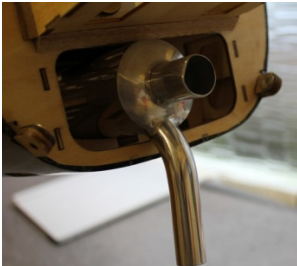

- Cut out the area for the engine cylinder head and the exhaust outlet on a piece of thin card and tape this to the fuselage at one end.



- Remove the engine and fit the cowl, then fold the card back over.



- Mark the area and cut out using a dremel. Ensure that enough air can get out of the cowl. The ration is usually, 3 time out to 1 in.
- Fit the ignition on the side of the motor box. Use Velcro and also a strap to ensure it does not come off with vibration.
- The cowl is fixed in 4 places, 2 at the top and 2 at the bottom. Place masking tape over the bottom 2 and pierce where the blind nut hole is.





- Refit the cowl and drill where the marked hole was.



- The fuel tank is pre-installed. Attach petrol proof pipe as per labelling on tank

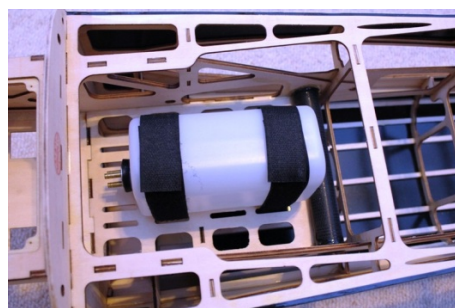

- Use the supplied pushrod with a ball joint to connect to the throttle arm on the engine. Then find a convenient place to locate the throttle servo using the supplied mount.

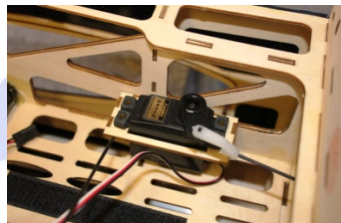

- Install the engine box cover plate once all connections have been made for the engine.



Electric

- Assemble the supplied electric motor box and bolt to the engine bulkhead.

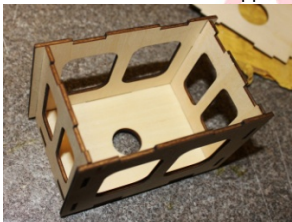

- Depending on the length of your motor you may need to use the supplied round plywood spacers to achieve the correct length for the motor.

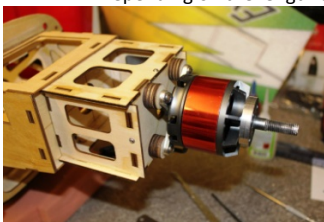

- Mount the ESC in airflow on the side of the electric motor mount, using a velcro strap.



- With the removal of the fuel tank it leaves a large area where the batteries can be mounted.

Switch

- On each side of the fuselage near the canopy bolts are areas for switches to be mounted.



RX

- A convenient place to mount the RX is just in front of the rudder servo. Ensure that it is mounted on velcro and strapped down.

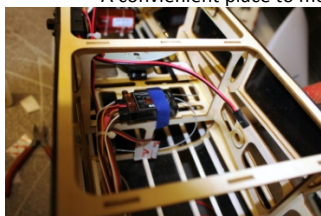

Canopy

- The canopy is held in place with the 2 thumb screws, ensure these are tight before flying



Set-up

We highly recommend the use of both dual rates and exponential. This will allow the model to fly both precision and 3D at the flick of a switch.

	Low Rates	Exponential	High Rate	Exponential
Elevator	15-20 deg	15-20 %	35-45 deg	45-60 %
Ailerons	15-20 deg	15-20 %	35-45 deg	45-60 %
Rudder	25-30 deg	15-20 %	35-45 deg	45-60 %

For test flights always use low rates, remember that + and - exponential is different per manufacturer, check your TX manual. Always check the range on your model before the maiden flight. Carry out a short flight then go over everything to make sure nothing has come loose.

CG Location

We suggest for initial test flights set the CG 111mm or 4 3/8 inches from the leading edge of the wing. Adjust after first flights to personal preference.

CG: 111mm (4 3/8 inches)

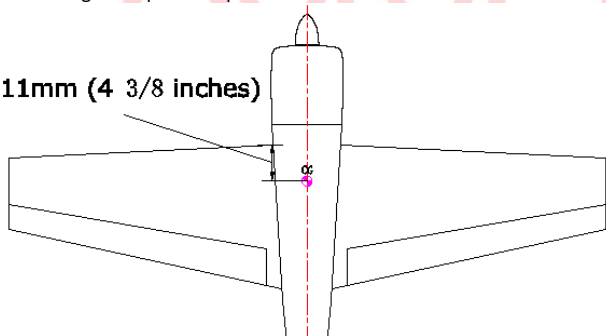



Ae

RC