

# Edge 540 V3 92"

**Item No : L-G035016**

**Specifications**

Wing Span	92" (2360mm)
Length	86 1/3 " (2193mm) (no include spinner)
Wing Area	1621.3 sq in(104.6sq dm)
Flying Weight	7100-7800g
Gasoline	50-60cc, DA50,DA60, DLE55, DLE60, 3W55
Radio	4CH/6S

**Description**

Carbon Fibre : Wing tube and sleeves, landing gear, tail gear;  
Fibreglass servo arms, horn and reinforced U/C mounting  
Scale read deck  
Canister ready tunnel  
Pre plumbed tank  
Adjustable pushrods  
Ringed cowl  
Pre drilled hinges  
Removeable Stabs and Rudder

**Colour schemes**



Scheme A



Scheme A

## Unpacking

Carefully unpack the model making sure that if you use a sharp knife to open bags, not to cut any covering on the model. Inspect each item to make sure no transit damage has happened. If you are not happy with any part or are unsure please contact the Dealer that you purchased from.

## Covering

Due to the model spending time in different climates zones from the factory on its way to you, some of the covering may have wrinkles. We highly recommend that you take time to re-seal all covering edges with an iron and to use a heat gun to remove any wrinkles and re-tighten the covering. It is best to do this now while the plane is not assembled, remember to not let any heat get near any parts like the canopy or cowl as this may cause damage.

**Note: Do not let any heat get near parts like the canopy or cowl as this may cause damage.**

## Assembly Tips

We also recommend that you go over all the accessible joints with cyano glue. Wick glue into areas of high stress around the U/C plate and motor box.

Use a thread locker on all metal-to-metal joints. Even if you are using electric with low vibration levels it will make sure that things do not drop off your airplane!



AeroPlus RC

## Landing Gear Assembly

- To help prevent the fuselage from being damaged while the model is being assembled we

**Note - Before beginning assembly be sure to determine your left and right wheel pants.**

- First, glue the thin wood wheel spacer to the inside of the wheel pant on what will be the outer side of the pant. Use the bolt to help centre the spacer



- Next, insert the bolt from what will be the outside of the wheel pant; put one thicker wood spacer on to the axle bolt, followed by the wheel and one more wood spacer.



- Install a lock washer onto the axle-bolt, followed by a washer.

**Note- you must place the washer now as it will be impossible to place once the axle is tightened.**



- Tighten down the bolt holding the locknut.

**Note – Do not over tighten. This will prevent the wheel from turning.**

- Insert the protruding bolts through the landing gear hole.
- Tighten up using a washer and lock nut.

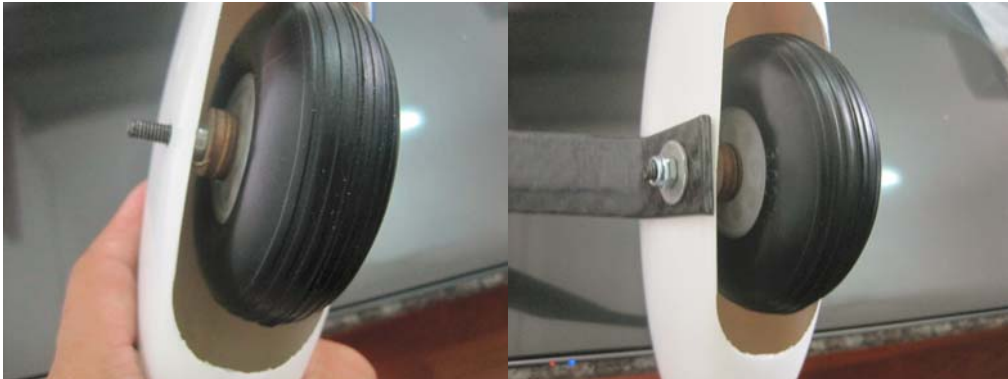

- Repeat for other side.

## Horizontal Stab

- First, remove the covering where the elevator horns fit into the stab, use either a soldering iron or a sharp hobby knife.



- Test fit the horns before gluing; some adjustment may be needed.
- The area of the horns that goes inside the elevator needs to be roughed up with sandpaper before gluing. This will result in a better glue joint.



- Glue the horns in place using epoxy glue or CA. Put a bolt through the ball joint hole to make sure that the horns stay in alignment while drying.

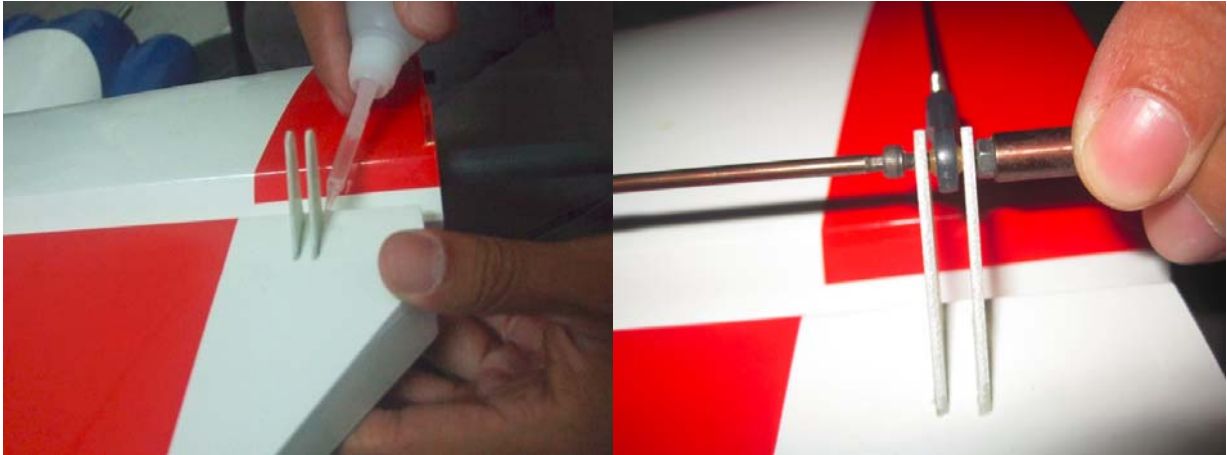

- Before fitting the elevator servo fix an extension lead so that the wire can be routed through the fuselage. Be sure to secure the coupling.

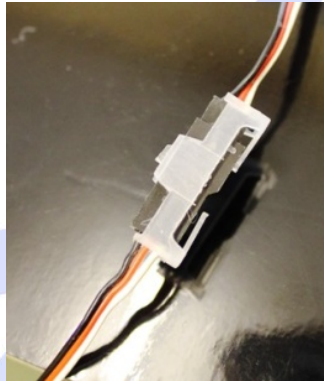

- Remove the covering for the elevator servo



- Fit the Elevator Servo and, using a fine drill, drill holes for the servo screws. Remove the servo and drop thin C.A. into all 4 holes after first threading the servo..



- Re-fit the elevator servo and secure it in with servo screws after the. Glue fully dries.



- Centre the servo using your TX, and fit a servo arm. Use either an aftermarket arm or attach the arms that were supplied to a servo head. Screw ball joints onto the pushrod (use pliers to hold pushrod) and bolt in place with supplied bolts. Centre of servo should align with elevator flat to the stab.



## Rudder

- Remove the covering where the rudder horns push through with either a knife or soldering iron.

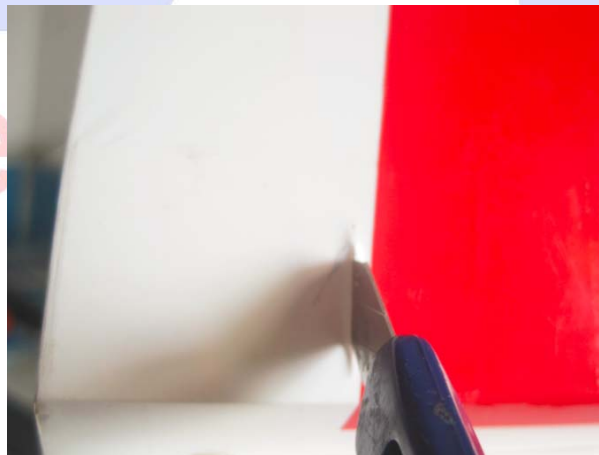

- Test fit the rudder horns

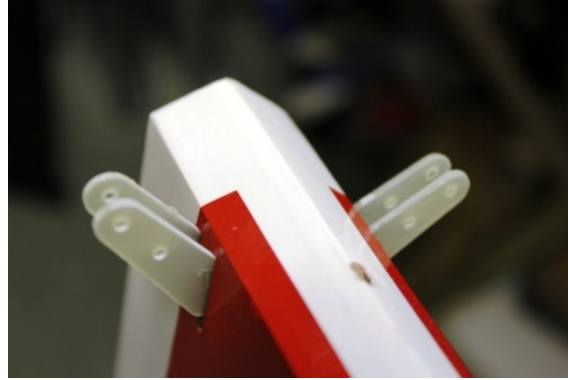

- Sand the area on the horn that fits inside the rudder so the glue bonds better



- Insert the easy removal pin into the pin hinges.



- Glue the rudder horns through the rudder with epoxy; wipe off excess glue while it is wet. Use the ball joint and bolt while gluing to maintain alignment. While still movable, measure that the same amount pushes out each side. Care needs to be taken here, otherwise your rudder geometry will be incorrect.



- Assemble the rudder servo control arm as below, drill holes for screws and use cyno to stop the nuts from coming loose.



- Fit the rudder servo and drill holes using a fine drill for the servo screws, drop thin cyno into the holes to strengthen the wood.

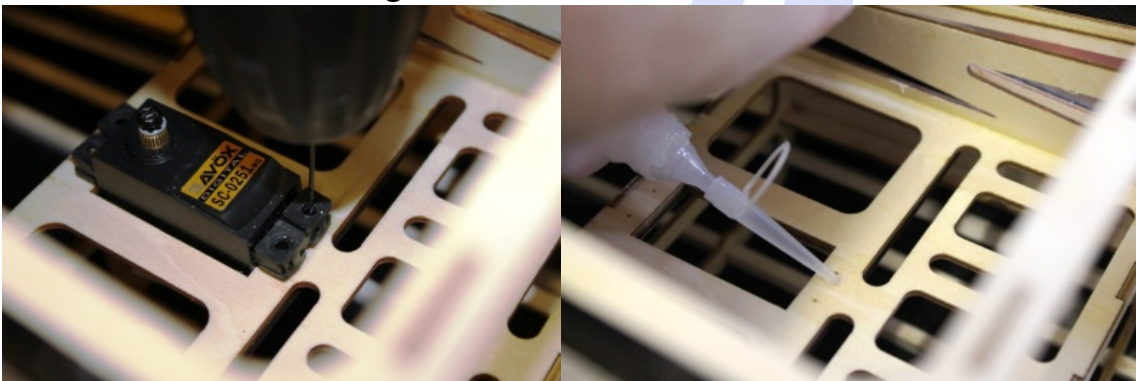

- Using servo screws fix the servo in place, note the spline is towards the front of the plane



- The closed loop wires are assembled in the plane; attach the rear ball joints to the rudder. Do this to both sides.





- Fit the arm onto the rudder servo and crimp the wires to a taut tension



## Tail Gear

- Locate all parts as in picture. When assembling, remember to do a thread locker on all parts



- Assemble the Gear as per photo

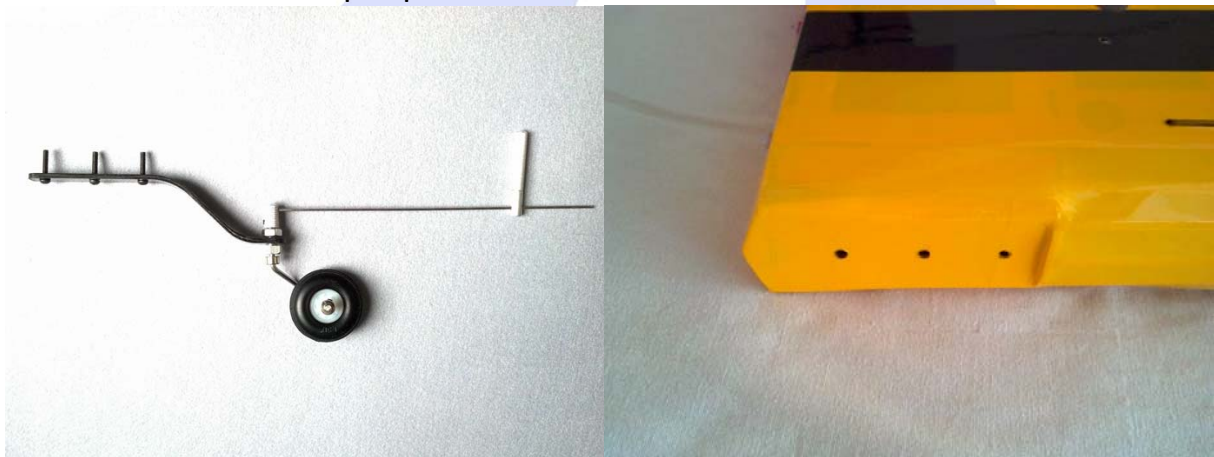

- Screw the CF gear on with the three supplied self tapping screws.



- Drill a hole in the base of the rudder for the rudder steering guide.



- Before gluing with cyano, place it over the thin rod.



## Aileron Servos

- The ailerons on the wings are pre-glued. Check each one by gently pulling to make sure that they are secure
- Remove the covering where the aileron horns are glued in place. Use either a soldering iron or a sharp knife

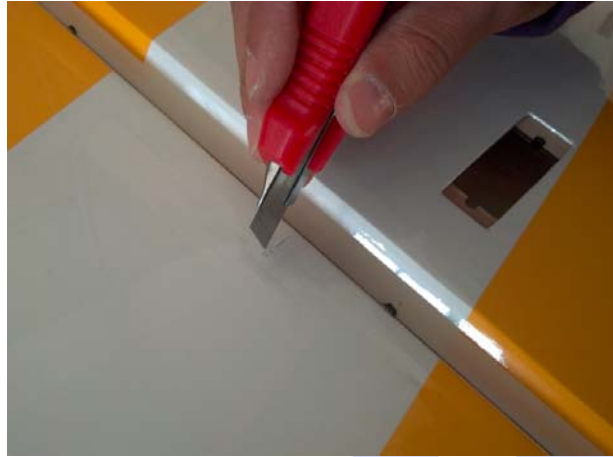

- Using sand paper rough the area that will be glued into the aileron.



- Glue both horns in with epoxy glue, use a bolt through the horns when gluing to make sure the alignment is correct.



- Fit the aileron servo and drill fine holes where the servo screws will fit. Then apply thin cyano to strengthen the holes.

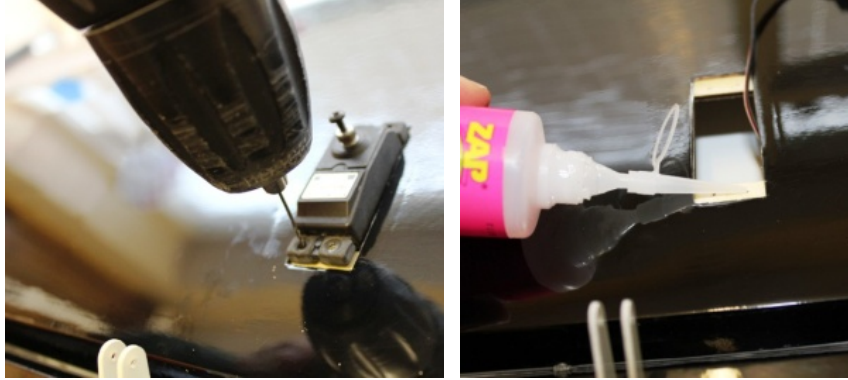

- If required install a servo extension lead onto the servo, remember to use a servo plug clip.

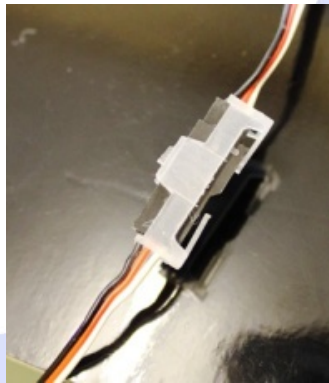

- Fit the servo and centre the servo arm.

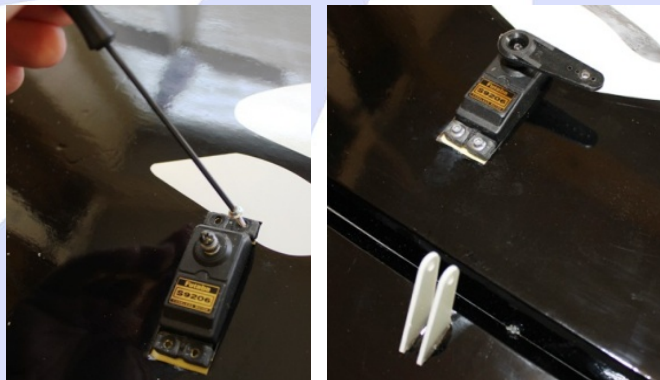

- Using the pushrod supplied screw ball joints onto each end. The correct length will leave the aileron lined up to the inner part still attached to the wing.



- Using supplied bolts attach the pushrod at both ends. Check to see you have sufficient movement of the aileron. If not adjust.



- Carry out the same procedure on the other wing.

## Gas Engine

- From the template that came with the engine, using the cross axis on the engine box mark the mounting holes.



- Check the diameter of the required bolts and drill accordingly.



- Mount the engine with the stand offs to the bulkhead. Remember to use large washers on the inside to spread the load and use plenty of nutlock.



- Exhaust options. Depending on the engine many exhaust options are available. Standard muffler, Pitts Exhaust of canister with header.

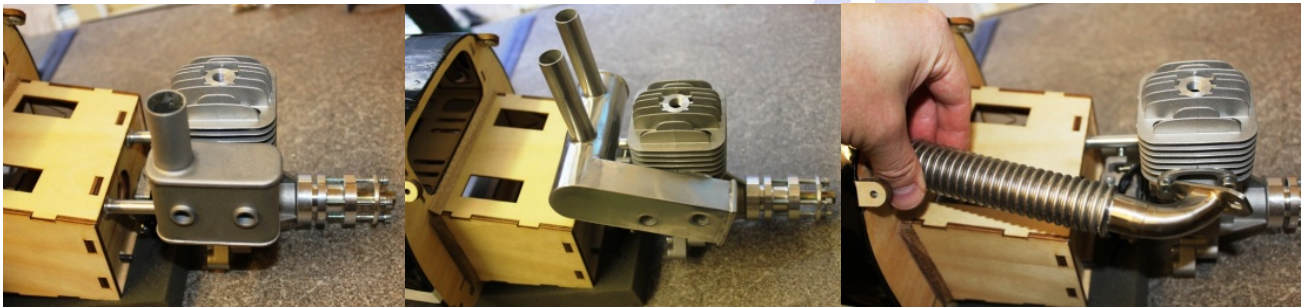

- Cut out the area for the engine cylinder head and the exhaust outlet on a piece of thin card and tape this to the fuselage at one end.



- Remove the engine and fit the cowl, then fold the card back over.

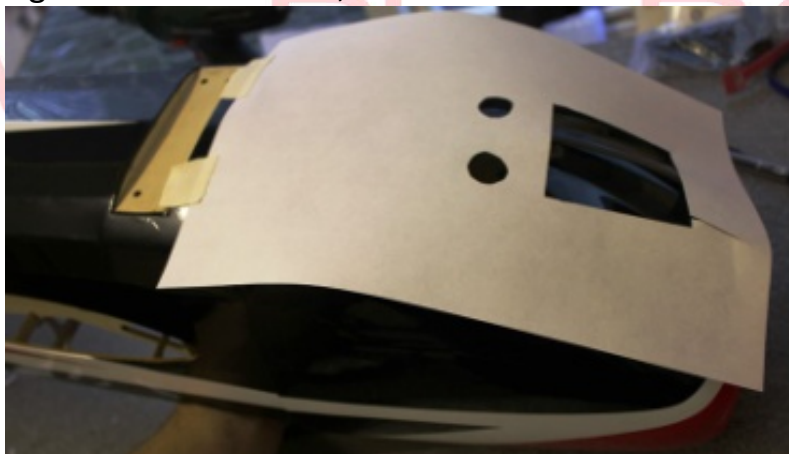

- Mark the area and cut out using a dremel. Ensure that enough air can get out of the cowl. The ration is usually, 3 time out to 1 in.

- Fit the ignition on the side of the motor box. Use Velcro and also a strap to ensure it does not come off with vibration.
- The cowl is fixed in 4 places, 2 at the top and 2 at the bottom. Place masking tape over the bottom 2 and pierce where the blind nut hole is.

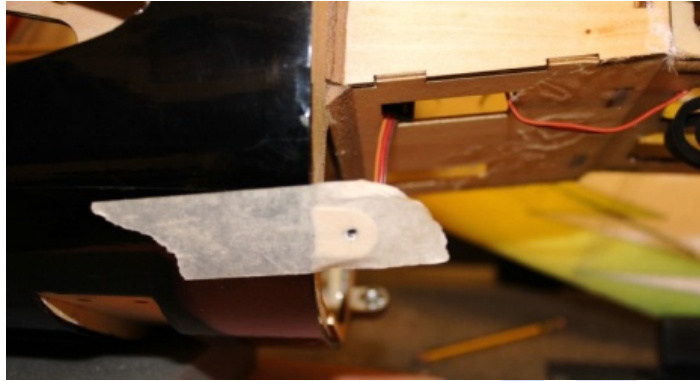

- Refit the cowl and drill where the marked hole was.



- The fuel tank is pre-installed. Attach petrol proof pipe as per labelling on tank



- Use the supplied pushrod with a ball joint to connect to the throttle arm on the engine. Then find a convenient place to locate the throttle servo using the supplied mount.



- Install the engine box cover plate once all connections have been made for the engine.



### Switch

- On each side of the fuselage near the canopy bolts are areas for switches to be mounted.



### RX

- A convenient place to mount the RX is just in front of the rudder servo. Ensure that it is mounted on velcro and strapped down.





## Canopy

- The canopy is held in place with the 2 thumb screws, ensure these are tight before flying



## Set-up

We highly recommend the use of both dual rates and exponential. This will allow the model to fly both precision and 3D at the flick of a switch.

	Low Rates	Exponential High Rate	Exponential	
Elevator	15-20 deg	15-20 %	35-45 deg	45-60 %
Ailerons	15-20 deg	15-20 %	35-45 deg	45-60 %
Rudder	25-30 deg	15-20 %	35-45 deg	45-60 %

For test flights always use low rates, remember that + and – exponential is different per manufacturer, check your TX manual.

Always check the range on your model before the maiden flight. Carry out a short flight then go over everything to make sure nothing has come loose.

## CG Location

We suggest for initial test flights set the CG 135.5mm or 5 1/3 inches from the leading edge of the wing.

Adjust after first flights to personal preference.

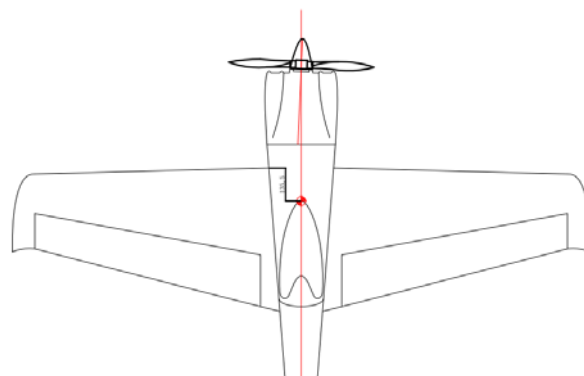

Enjoy Flying!!



AeroPlus RC